

## Bock HC Compressors

Semi-hermetic Compressors for Hydrocarbons

## Differences to a standard compressor

Electronic motor protection MP10 **enclosed** for installation in the switch cabinet



Oil sump heater as standard

Heat protection thermostat as standard

Special oil charge Synth 68

### Type key - compressors for hydrocarbons

HG34P / 380 - 4 S HC

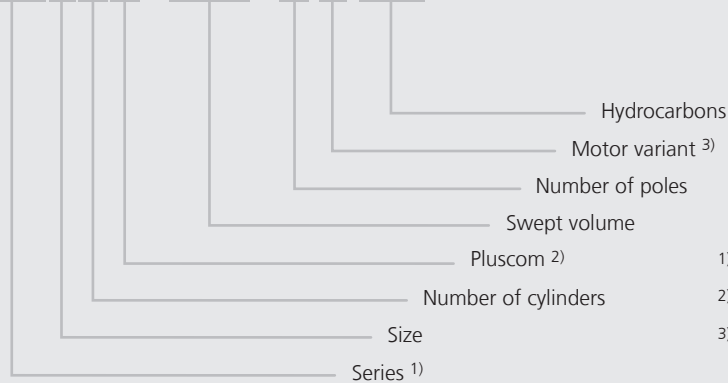

- 1) HG = Hermetic Gas-cooled (suction gas-cooled)
- 2) = Additional declaration for Pluscom compressors
- 3) S = More powerful motor e.g. air-conditioning applications

## Overview hydrocarbons

Refrigerant	Composition (Formula)	Name	ODP [R11=1,0]	GWP <sub>(100a)</sub> <sup>② ③</sup> [CO <sub>2</sub> =1,0]	Safety group <sup>①</sup>	Critical value [kg/m <sup>3</sup> ] <sup>②</sup>
R290	C <sub>3</sub> H <sub>8</sub>	Propane	0	3	A3	0,008
R1270	C <sub>3</sub> H <sub>6</sub>	Propylene	0	3	A3	0,008
R600a	C <sub>4</sub> H <sub>10</sub>	Isobutane	0	3	A3	0,011

① Classification according to EN378-1 or ASHRAE 34  
 ② According to EN378-1  
 ③ Time horizon 100 years - according to IPCC II (1996) → Basis for Kyoto protocol

R290		Performance data											50 Hz	
Type	Cond. temp. °C		Cooling capacity $\dot{Q}_0$ [W]					Power consumption $P_e$ [kW]						
			Evaporating temperature °C											
			12,5	10	7,5	5	0	-5	-10	-15	-20	-25	-30	-35
HG12P/60-4 S HC	30	Q	6138	5662	5213	4789	4017	3335	2736	2210	1750	1347	993	677
		P	0,78	0,81	0,83	0,84	0,85	0,83	0,80	0,75	0,69	0,63	0,58	0,53
	40	Q	5282	4865	4472	4102	3427	2831	2306	1844	1434	1070		
		P	1,04	1,04	1,04	1,03	1,00	0,95	0,88	0,81	0,74	0,68		
	50	Q	4506	4144	3804	3483	2899	2382	1923	1516				
		P	1,25	1,23	1,21	1,18	1,11	1,04	0,96	0,88				
HG12P/75-4 HC HG12P/75-4 S HC	30	Q	7616	7025	6468	5942	4984	4138	3394	2742	2172	1672	1231	840
		P	0,96	1,00	1,03	1,05	1,05	1,03	0,99	0,93	0,86	0,78	0,71	0,65
	40	Q	6554	6036	5549	5090	4252	3513	2862	2287	1780	1328		
		P	1,29	1,30	1,29	1,28	1,24	1,17	1,10	1,01	0,92	0,84		
	50	Q	5591	5142	4720	4322	3597	2955	2386	1880				
		P	1,55	1,53	1,50	1,47	1,38	1,29	1,19	1,09				
HG12P/90-4 HC HG12P/90-4 S HC	30	Q	9094	8388	7722	7095	5950	4940	4053	3275	2593	1996	1470	1003
		P	1,15	1,20	1,23	1,25	1,26	1,23	1,18	1,11	1,02	0,94	0,85	0,78
	40	Q	7825	7207	6625	6077	5077	4195	3417	2731	2125	1586		
		P	1,54	1,55	1,54	1,53	1,48	1,40	1,31	1,21	1,10	1,01		
	50	Q	6675	6140	5635	5161	4294	3528	2849	2245				
		P	1,85	1,83	1,79	1,75	1,65	1,54	1,42	1,30				
HG12P/110-4 HC HG12P/110-4 S HC	30	Q	10685	9856	9074	8337	6992	5805	4762	3848	3047	2345	1728	1179
		P	1,35	1,41	1,44	1,47	1,48	1,45	1,39	1,30	1,20	1,10	1,00	0,92
	40	Q	9195	8469	7785	7141	5966	4929	4015	3209	2497	1863		
		P	1,81	1,82	1,81	1,80	1,74	1,65	1,54	1,42	1,30	1,18		
	50	Q	7844	7214	6621	6064	5046	4146	3348	2638				
		P	2,18	2,15	2,10	2,06	1,94	1,81	1,67	1,53				
HG22P/125-4 HC HG22P/125-4 S HC	30	Q	12617	11638	10715	9845	8256	6855	5623	4543	3598	2770	2040	1392
		P	1,60	1,66	1,70	1,73	1,74	1,71	1,64	1,54	1,42	1,30	1,18	1,08
	40	Q	10857	10000	9192	8432	7044	5820	4741	3790	2949	2200		
		P	2,14	2,15	2,14	2,12	2,05	1,94	1,82	1,67	1,53	1,40		
	50	Q	9262	8519	7819	7160	5958	4895	3954	3115				
		P	2,57	2,53	2,49	2,43	2,29	2,13	1,97	1,80				
HG22P/160-4 HC HG22P/160-4 S HC	30	Q	15573	14364	13225	12151	10190	8461	6940	5608	4441	3418	2518	1718
		P	1,97	2,05	2,10	2,14	2,15	2,11	2,02	1,90	1,75	1,60	1,46	1,34
	40	Q	13401	12343	11346	10407	8694	7183	5851	4677	3639	2715		
		P	2,64	2,65	2,64	2,62	2,53	2,40	2,24	2,07	1,89	1,72		
	50	Q	11432	10514	9650	8838	7354	6042	4880	3845				
		P	3,18	3,13	3,07	3,00	2,83	2,63	2,43	2,22				
HG22P/190-4 HC HG22P/190-4 S HC	30	Q	18756	17300	15928	14634	12273	10190	8359	6754	5349	4117	3033	2070
		P	2,38	2,47	2,53	2,57	2,59	2,54	2,43	2,28	2,11	1,93	1,76	1,61
	40	Q	16140	14865	13664	12534	10471	8651	7047	5633	4383	3270		
		P	3,18	3,19	3,18	3,15	3,05	2,89	2,70	2,49	2,27	2,07		
	50	Q	13768	12663	11623	10644	8857	7277	5877	4631				
		P	3,82	3,77	3,69	3,61	3,40	3,17	2,92	2,68				
HG34P/215-4 HC HG34P/215-4 S HC	30	Q	21370	19712	18148	16674	13984	11610	9524	7695	6094	4691	3456	2358
		P	2,71	2,81	2,89	2,93	2,96	2,90	2,77	2,60	2,41	2,20	2,00	1,83
	40	Q	18389	16937	15569	14281	11931	9857	8030	6419	4994	3726		
		P	3,62	3,64	3,62	3,59	3,47	3,29	3,07	2,84	2,59	2,36		
	50	Q	15687	14428	13243	12128	10092	8292	6697	5277				
		P	4,36	4,29	4,21	4,11	3,88	3,61	3,33	3,05				
HG34P/255-4 HC HG34P/255-4 S HC	30	Q	25121	23172	21333	19601	16438	13648	11196	9046	7164	5514	4062	2772
		P	3,18	3,30	3,39	3,45	3,47	3,40	3,26	3,06	2,83	2,59	2,36	2,15
	40	Q	21617	19910	18302	16788	14025	11587	9439	7545	5870	4380		
		P	4,26	4,27	4,26	4,22	4,08	3,87	3,61	3,33	3,05	2,78		
	50	Q	18441	16961	15567	14256	11863	9747	7871	6202				
		P	5,12	5,05	4,95	4,83	4,56	4,25	3,91	3,59				
HG34P/315-4 HC HG34P/315-4 S HC	30	Q	31032	28624	26353	24213	20306	16859	13830	11175	8850	6812	5018	3425
		P	3,93	4,08	4,19	4,26	4,29	4,20	4,03	3,78	3,49	3,20	2,91	2,66
	40	Q	26704	24595	22609	20738	17326	14314	11660	9321	7252	5411		
		P	5,26	5,28	5,26	5,21	5,04	4,78	4,46	4,12	3,76	3,43		
	50	Q	22780	20952	19231	17611	14655	12041	9724	7662				
		P	6,33	6,23	6,11	5,97	5,63	5,25	4,84	4,43				
HG34P/380-4 HC HG34P/380-4 S HC	30	Q	37625	34705	31952	29357	24620	20441	16768	13548	10729	8259	6083	4151
		P	4,77	4,95	5,08	5,16	5,20	5,10	4,88	4,58	4,24	3,87	3,53	3,23
	40	Q	32377	29820	27411	25144	21006	17355	14137	11300	8792	6560		
		P	6,38	6,40	6,38	6,32	6,11	5,80	5,41	4,99	4,56	4,16		
	50	Q	27619	25402	23315	21352	17768	14597	11789	9289				
		P	7,67	7,56	7,41	7,24	6,83	6,36	5,86	5,37				

Relating to 20 °C suction gas temperature without liquid subcooling

 Supplementary cooling or red. suction gas temperature

 Motor version -S- (more powerful motor)

R1270		Performance data											50 Hz	
Type	Cond temp. °C		Cooling capacity $\dot{Q}_0$ [W]					Power consumption $P_e$ [kW]						
			Evaporating temperature °C											
			12,5	10	7,5	5	0	-5	-10	-15	-20	-25	-30	-35
HG12P/60-4 S HC	30	Q	7327	6760	6224	5720	4798	3986	3274	2650	2105	1629	1213	846
		P	0,93	0,95	0,97	0,99	1,00	0,99	0,97	0,92	0,87	0,80	0,73	0,65
	40	Q	6391	5887	5412	4965	4149	3430	2796	2238	1747	1312		
		P	1,24	1,24	1,24	1,23	1,21	1,16	1,10	1,03	0,95	0,85		
	50	Q	5483	5042	4628	4237	3525	2897	2341	1849				
		P	1,51	1,49	1,47	1,44	1,38	1,30	1,21	1,11				
HG12P/75-4 HC HG12P/75-4 S HC	30	Q	9091	8387	7722	7096	5954	4946	4062	3288	2612	2022	1505	1049
		P	1,15	1,18	1,21	1,23	1,24	1,23	1,20	1,15	1,08	0,99	0,90	0,80
	40	Q	7930	7305	6715	6161	5148	4255	3469	2777	2167	1627		
		P	1,54	1,54	1,54	1,53	1,50	1,44	1,36	1,27	1,17	1,06		
	50	Q	6803	6256	5742	5257	4374	3594	2905	2294				
		P	1,87	1,85	1,82	1,79	1,71	1,61	1,50	1,38				
HG12P/90-4 HC HG12P/90-4 S HC	30	Q	10855	10014	9221	8473	7109	5906	4850	3925	3118	2414	1797	1253
		P	1,37	1,41	1,44	1,46	1,48	1,47	1,43	1,37	1,29	1,19	1,08	0,96
	40	Q	9468	8722	8018	7356	6147	5081	4142	3316	2588	1943		
		P	1,83	1,84	1,84	1,83	1,79	1,72	1,63	1,52	1,40	1,27		
	50	Q	8123	7470	6856	6278	5223	4291	3468	2739				
		P	2,24	2,21	2,18	2,14	2,04	1,93	1,79	1,64				
HG12P/110-4 HC HG12P/110-4 S HC	30	Q	12755	11767	10834	9956	8353	6939	5698	4612	3664	2836	2111	1472
		P	1,61	1,66	1,69	1,72	1,74	1,73	1,68	1,61	1,51	1,39	1,26	1,12
	40	Q	11125	10248	9422	8643	7223	5970	4867	3896	3041	2283		
		P	2,15	2,16	2,16	2,15	2,10	2,02	1,91	1,79	1,65	1,49		
	50	Q	9544	8777	8055	7376	6137	5042	4075	3218				
		P	2,63	2,60	2,56	2,51	2,40	2,26	2,10	1,93				
HG22P/125-4 HC HG22P/125-4 S HC	30	Q	15062	13895	12794	11757	9864	8194	6729	5447	4327	3349	2493	1738
		P	1,90	1,96	2,00	2,03	2,06	2,04	1,98	1,90	1,78	1,65	1,49	1,33
	40	Q	13138	12102	11126	10207	8529	7050	5747	4601	3591	2696		
		P	2,54	2,55	2,55	2,53	2,48	2,38	2,26	2,11	1,94	1,76		
	50	Q	11270	10365	9512	8710	7247	5954	4812	3800				
		P	3,10	3,07	3,02	2,97	2,83	2,67	2,49	2,28				
HG22P/160-4 HC HG22P/160-4 S HC	30	Q	18590	17149	15791	14511	12174	10114	8305	6722	5340	4134	3077	2145
		P	2,35	2,42	2,47	2,51	2,54	2,52	2,45	2,34	2,20	2,03	1,84	1,64
	40	Q	16215	14936	13732	12597	10527	8701	7093	5679	4432	3328		
		P	3,14	3,15	3,15	3,13	3,06	2,94	2,79	2,61	2,40	2,17		
	50	Q	13910	12793	11740	10750	8944	7349	5940	4690				
		P	3,83	3,79	3,73	3,66	3,50	3,30	3,07	2,82				
HG22P/190-4 HC HG22P/190-4 S HC	30	Q	22389	20654	19018	17476	14662	12181	10003	8096	6432	4979	3706	2584
		P	2,83	2,91	2,98	3,02	3,06	3,03	2,95	2,82	2,65	2,45	2,22	1,97
	40	Q	19529	17989	16538	15172	12679	10479	8543	6839	5338	4008		
		P	3,78	3,79	3,79	3,77	3,68	3,54	3,36	3,14	2,89	2,61		
	50	Q	16753	15407	14140	12947	10772	8851	7154	5649				
		P	4,61	4,56	4,49	4,41	4,21	3,97	3,69	3,39				
HG34P/215-4 HC HG34P/215-4 S HC	30	Q	25510	23533	21669	19912	16706	13879	11397	9225	7329	5673	4223	2944
		P	3,22	3,32	3,39	3,44	3,48	3,45	3,36	3,21	3,02	2,79	2,53	2,25
	40	Q	22251	20497	18844	17287	14446	11940	9734	7793	6082	4567		
		P	4,31	4,32	4,32	4,29	4,20	4,04	3,83	3,58	3,29	2,98		
	50	Q	19089	17555	16111	14753	12274	10085	8151	6437				
		P	5,26	5,20	5,12	5,03	4,80	4,52	4,21	3,86				
HG34P/255-4 HC HG34P/255-4 S HC	30	Q	29988	27664	25472	23408	19638	16315	13397	10844	8615	6668	4964	3461
		P	3,79	3,90	3,98	4,04	4,09	4,06	3,95	3,78	3,55	3,28	2,97	2,64
	40	Q	26157	24094	22151	20321	16982	14036	11442	9160	7149	5368		
		P	5,06	5,08	5,07	5,05	4,93	4,75	4,50	4,21	3,87	3,50		
	50	Q	22439	20636	18938	17341	14428	11855	9581	7566				
		P	6,18	6,11	6,02	5,91	5,64	5,32	4,95	4,54				
HG34P/315-4 HC HG34P/315-4 S HC	30	Q	37044	34173	31466	28915	24259	20154	16550	13396	10642	8237	6132	4275
		P	4,68	4,82	4,92	5,00	5,06	5,02	4,88	4,67	4,39	4,05	3,67	3,26
	40	Q	32311	29764	27363	25102	20977	17338	14135	11316	8831	6631		
		P	6,26	6,28	6,27	6,23	6,09	5,86	5,56	5,19	4,78	4,32		
	50	Q	27719	25492	23395	21422	17823	14644	11836	9347				
		P	7,63	7,54	7,43	7,30	6,97	6,57	6,11	5,61				
HG34P/380-4 HC HG34P/380-4 S HC	30	Q	44914	41434	38151	35058	29413	24436	20066	16242	12903	9987	7434	5183
		P	5,68	5,84	5,97	6,06	6,13	6,08	5,92	5,66	5,32	4,91	4,45	3,95
	40	Q	39176	36087	33176	30436	25434	21022	17137	13720	10707	8040		
		P	7,58	7,61	7,60	7,56	7,39	7,11	6,74	6,30	5,79	5,24		
	50	Q	33608	30908	28365	25973	21610	17756	14350	11332				
		P	9,25	9,15	9,01	8,85	8,45	7,97	7,41	6,80				

Relating to 20 °C suction gas temperature without liquid subcooling

 Supplementary cooling or red. suction gas temperature

 Motor version -S- (more powerful motor)

HC Type	Number of cylinders	Displacement 50 / 60 Hz (1450 / 1740 rpm)  m <sup>3</sup> /h	Electrical data				Weight  kg	Connections ⑥		Oil charge  Ltr.
			Voltage  ①	Max. working current ②  A  Δ / Y	Max. power consumption ②  kW	Starting current (rotor locked)  A  Δ / Y		Discharge line DV  mm   inch	Suction line SV  mm   inch	
HG12P/60-4 S HC	2	5,40 / 6,40	③	6,8 / 3,9	2,2	40 / 23	48	12   1/2	16   5/8	0,8
HG12P/75-4 HC	2	6,70 / 8,10	③	7,1 / 4,1	2,3	40 / 23	48	12   1/2	16   5/8	0,8
HG12P/75-4 S HC	2	6,70 / 8,10	③	8,0 / 4,6	2,6	43 / 25	49	12   1/2	16   5/8	0,8
HG12P/90-4 HC	2	8,00 / 9,60	③	8,5 / 4,9	2,8	43 / 25	49	12   1/2	16   5/8	0,8
HG12P/90-4 S HC	2	8,00 / 9,60	③	8,8 / 5,1	2,9	45 / 26	49	12   1/2	16   5/8	0,8
HG12P/110-4 HC	2	9,40 / 11,30	③	9,2 / 5,3	3,1	43 / 25	49	12   1/2	16   5/8	0,8
HG12P/110-4 S HC	2	9,40 / 11,30	③	10,6 / 6,1	3,6	45 / 26	49	12   1/2	16   5/8	0,8
HG22P/125-4 HC	2	11,10 / 13,30	③	9,3 / 5,4	3,0	69 / 40	74	16   5/8	22   7/8	1,0
HG22P/125-4 S HC	2	11,10 / 13,30	③	10,8 / 6,2	3,6	69 / 40	74	16   5/8	22   7/8	1,0
HG22P/160-4 HC	2	13,70 / 16,40	③	11,1 / 6,4	3,7	69 / 40	74	16   5/8	22   7/8	1,0
<b>HG22P/160-4 S HC</b>	<b>2</b>	<b>13,70 / 16,40</b>	<b>③</b>	<b>13,1 / 7,6</b>	<b>4,4</b>	<b>87 / 50</b>	<b>76</b>	<b>16   5/8</b>	<b>22   7/8</b>	<b>1,0</b>
HG22P/190-4 HC	2	16,50 / 19,80	③	13,8 / 8,0	4,8	69 / 40	74	16   5/8	22   7/8	1,0
HG22P/190-4 S HC	2	16,50 / 19,80	③	16,2 / 9,4	5,6	87 / 50	75	16   5/8	22   7/8	1,0
HG34P/215-4 HC	4	18,80 / 22,60	③	14,0 / 8,1	4,8	87 / 50	92	22   7/8	28   1 1/8	1,3
HG34P/215-4 S HC	4	18,80 / 22,60	③	18,3 / 10,5	6,0	132 / 76	97	22   7/8	28   1 1/8	1,3
HG34P/255-4 HC	4	22,10 / 26,60	③	17,0 / 9,8	6,0	87 / 50	91	22   7/8	28   1 1/8	1,3
HG34P/255-4 S HC	4	22,10 / 26,60	③	21,1 / 12,2	7,2	132 / 76	96	22   7/8	28   1 1/8	1,3
HG34P/315-4 HC	4	27,30 / 32,80	③	21,1 / 12,2	7,4	111 / 64	94	22   7/8	28   1 1/8	1,3
HG34P/315-4 S HC	4	27,30 / 32,80	③	25,5 / 14,7	8,9	132 / 76	97	22   7/8	28   1 1/8	1,3
HG34P/380-4 HC	4	33,10 / 39,70	③	26,1 / 15,1	9,3	111 / 64	93	22   7/8	28   1 1/8	1,3
HG34P/380-4 S HC	4	33,10 / 39,70	③	31,2 / 18,0	11,1	132 / 76	96	22   7/8	28   1 1/8	1,3

## Explanations

- ① Tolerance ( $\pm 10\%$ ) relates to the mean value of the voltage range. Other voltages and current types on request.
- ② - The specifications for max. power consumption apply for 50Hz operation. For 60Hz operation, the specifications have to be multiplied by the factor 1.2.  
The max. working current remains unchanged.  
- Take account of the max. operating current / max. power consumption when designing contactors, leads and fuses.  
Switches: service category AC3
- ③ 220-240 V  $\Delta$  / 380-420 V Y - 3 - 50 Hz  
265-290 V  $\Delta$  / 440-480 V Y - 3 - 60 Hz
- ④ 380-420 V Y/YY - 3 - 50 Hz PW  
440-480 V Y/YY - 3 - 60 Hz PW  
PW = Part Winding, motors for part winding start (no start unloaders required)  
- Winding ratio: HG4, HG5, HG6 = 66% / 33%  
- Designs for Y/ $\Delta$  on request
- ⑤ 380-420 V  $\Delta$ /YYY - 3 - 50 Hz PW  
440-480 V  $\Delta$ /YYY - 3 - 60 Hz PW  
PW = Part Winding, motors for part winding start (no start unloaders required)  
- Winding ratio: HG7, HG8 = 60% / 40%  
- Designs for Y/ $\Delta$  on request
- ⑥ For soldering connections

### Oil sump heater 110-240 V - 1 - 50/60 Hz

HG12P..HC, HG22P..HC, HG34P..HC: 50-120 W  
PTC heater, self-regulating, installation in housing bore

### Oil sump heater 230 V - 1 - 50/60 Hz

HG4..HC: 80 W  
HG5...HC, HG6...HC, HG7...HC: 140 W  
HG8..HC: 200 W  
Permanently set version, installation in immersion sleeve

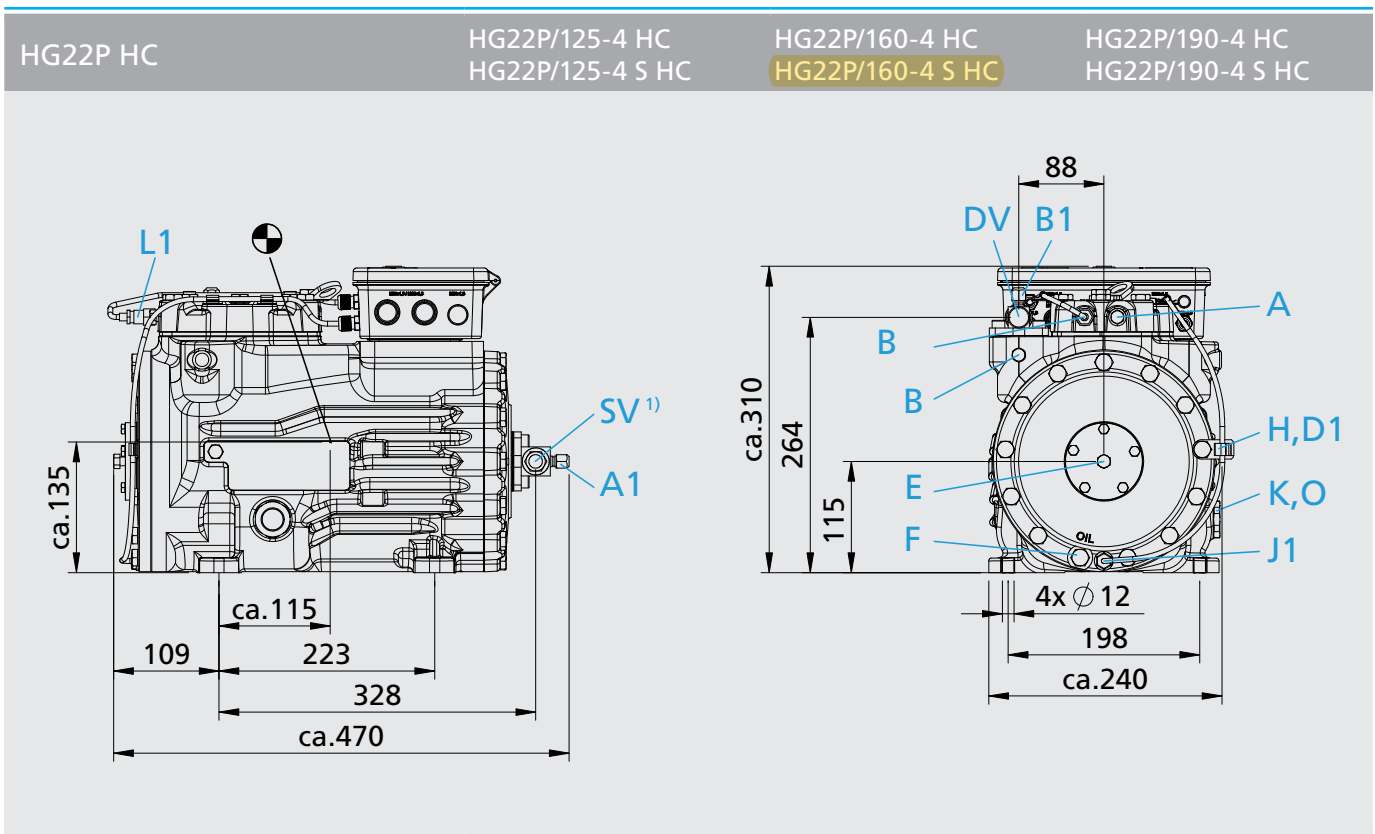
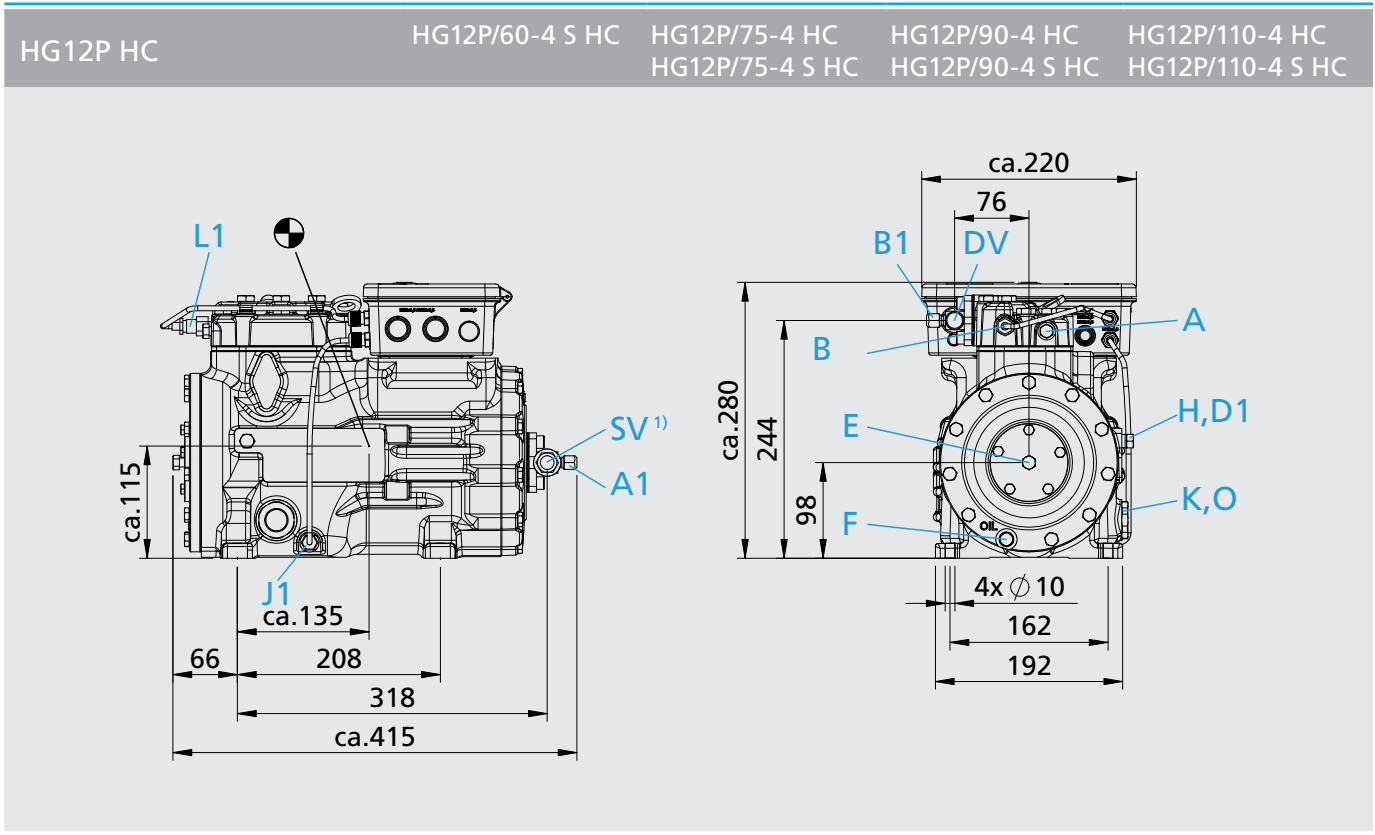

<sup>1)</sup> SV 90° rotatable  
 ☉ Centre of gravity

Dimensions in mm